

**Christian Ulrik Andersen & Søren Bro Pold**

*Participatory IT Research Center, CAVI*

*Aarhus University, Denmark*

## **Post-digital Books and Disruptive Literary Machines**

Digital Literature Beyond the Gutenberg and Google Galaxies

### **Résumé**

L'e-book a été lancé plusieurs fois durant la dernière décennie et on a souvent prédit la mort du livre. Par ailleurs, la littérature numérique et la littérature en ligne ont déjà une longue histoire. Nous sommes cependant témoins actuellement de plusieurs expériences artistiques et littéraires intéressantes qui explorent les modifications actuelles de la culture littéraire et y compris les modifications au niveau des médias impulsées par la percée populaire récente de l'e-book et les changements dans le commerce des livres tels que représentés par exemple par le Kindle d'Amazon et l'ibook d'Apple. Plusieurs de ces projets intègrent le livre imprimé sous de nouvelles formes en tant que composante de l'exploration.

Notre article se focalise sur la façon dont les expériences artistiques en littérature numérique explorent cette nouvelle culture littéraire à travers des expérimentations formelles qui enrichissent le livre et / ou l'expérience artistique avec l'économie littéraire post-numérique. Il prend comme exemples: *The Project Formerly Known as Kindle Forkbomb* d' *Ubermorgen*, le livre d'artiste multimedia *Affected as Only a Human Can Be* de Konrad Korabiewski et Litten (version danoise de 2010, version anglaise à paraître) et notre propre installation collaborative *Accidentally, the Screen Turns to Ink*. L'article discute la façon dont ces projets explorent la façon dont la littérature prend part à un processus de production post-capitaliste à travers des plateformes de consommation. Si la presse écrite a été la première courroie de transmission et, par là, une partie intégrante du développement capitaliste industriel, l'article esquisse la façon par laquelle les technologies littéraires contemporaines s'intègrent à la réflexion sur et au développement

d'un post- ou semio- capitalisme. Il discute également de la façon dont la littérature fonctionne dans une culture logicielle post-industrielle telle que présentée par Apple, Amazon et Google.

**Mots clés :** littérature numérique, Kindle, Apple, Ubermorgen, Korabiewski, post-digital, post-capitaliste, consommation contrôlée.

### **Abstract**

The e-book has been launched several times during the last decades and the book's demise has often been predicted. Furthermore networked and electronic literature has already established a long history. However, currently we witness several interesting artistic and literary experiments exploring the current changes in literary culture ó including the media changes brought about by the current popular break-through of the e-book and the changes in book trading such as represented by e.g. Amazon's Kindle and Apple's iBooks. Several of these project include the printed book in new ways as part of the exploration.

This article focuses on how artistic, e-literary experiments explore this new literary culture through formal experiments with expanded books and/or artistic experiments with the post-digital literary economy. Examples are Ubermorgen's *The Project Formerly Known as Kindle Forkbomb*, Konrad Korabiewski and Litten's multimedia art book *Affected as Only a Human Can Be* (Danish version, 2010, English version forthcoming) and our own collaborative installation *Accidentally, the Screen Turns to Ink*. The article discusses how these projects explore how literature currently becomes part of a post-capitalistic production process through controlled consumption platforms. If the printing press was the first conveyor belt and thus an integral part of developing industrial capitalism, then this article sketches out how contemporary literary technologies is integral to the development of óand critical reflection on post- or semio-capitalism, and furthermore we will discuss how literature functions in a post-industrial software culture such as the one presented by Apple, Amazon and Google.

**Keywords:** digital literature, Kindle, Apple, Ubermorgen, Korabiewski, post-digital, post-capitalist controlled consumption.

## Introduction

With the digitisation of text, the print book's demise has often been predicted. Literary theorist, Jay David Bolter soon after the popularisation of hypertext argued that we live in the late age of print and that « the evidence of senescence, if not senility, is all around us. »<sup>1</sup> However, today the book does not seem quite dead yet. Through tablet computing, and in particular Amazon's businesses that offer a market place for books, direct publishing and self-publishing we are witnessing the proliferation of both traditional books, e-books and print on demand books. In this sense, we are in the age of *Post-Digital Print*, as the recent title of Alessandro Ludovico's book suggests.<sup>2</sup> But how are we to understand what is now 'post' in 'digital print'?

The term 'post-digital' was first introduced by the computer musician Kim Cascone in 2000 as a way of describing the aesthetics of errors and failure including phenomena such as glitch as « a collection of deconstructive audio and visual techniques that allow artists to work beneath the previously impenetrable veil of digital media. »<sup>3</sup> With a reference to Nicholas Negroponte, Cascone argues that the digital revolution is over. This does not mean that he wants to do away with digital media, nor that he envisions a future predetermined by the digital, but rather that digital media holds less fascination. Through commercialisation, it has been embedded in almost every contemporary aesthetic practice (« cranking out digital fluff by the gigabyte »). In stating that the medium is no longer the message, and that the specific tools themselves have become the message, Cascone captures an important aspect of glitch art and in a broader perspective also software art, which was important at the time.

Perhaps Cascone was foresighted? At least, the distinction between analogue and digital, or online and offline makes less sense today, and the digital medium does not primarily appear as a separate form of existence (for instance, contrasted an analogue form of existence). In the afterword to Ludovico's book, *Post-Digital Print*, the technology theorist Florian Cramer argues that the medium of the book has always been the subject of change (from papyrus scrolls, to print books, to now e-books). We need to understand that the book is merely a 'symbolic form' (in this, Cramer refers to Ernst Cassirer) that can migrate to different media. 'Print' is in this sense only a carrier of information, a medium.<sup>4</sup>

Our main argument is that to focus on the medium of the book (the print book), as the only precursor to the digital book (the e-book) will miss the point.

We also need to focus on the symbol activity that makes books, the writing of texts (authors do not write books, Cramer notes, but texts). However, this writing is no longer merely a human activity (a practise of human language), but also the outcome of a software system that is intrinsic to the writing of digital text formats (the practice of code and computation). Our approach is in line with software artsø call to reflect the tool rather than the medium, as expressed by Kim Cascone. Today, however, our tools of writing have become embedded in a machinery of text, the contemporary ÷printing pressø (from Google to Amazon), and in this sense the manufacturing process of words become the centre of our attention. Similarly to a notion of literature as a reflexion on what makes language (the symbol activity of language), contemporary literary experiments may reflect, and challenge this production of language and text that takes place in the Google galaxy.

In other words, with the normalisation of e-books, what is changing (what is ÷postø in the ÷post-digital bookø) is not just the digitisation of books, but more significantly the ecology and infrastructure in and around books ô and how Google, Amazon, YouTube, etc. have become embedded in the foundations of our culture of writing and of books (from libraries to universities). It is this infrastructure that we want to address in this paper, its implications, and how it is currently being reflected and scrutinized in contemporary digital literature. But let us first delve into a deeper understanding of the paradoxes of post-digital books that e-literature may address.

### **Revolution or reaction?**

As a cultural phenomenon, the book is caught in between being, on the one hand, an endless maze and a ÷garden of forking pathsø (as Jorge Louis Borges reminds us), and on the other, singular objects with clear and copyrighted authority. The digitisation of text has often been associated with the maze, and a networked, hypertextual infrastructure. For instance, Noah Wardrip-Fruin and Nick Montfort begin their *New Media Reader* with Borgesø text, arguing that even though Borges did not write a hypertext, he invented the hypertext novel as a theory well before the public disclosure of the computer. He encoded the idea of ÷fictionø as a theory of a universe in which everything can happen, a theory of a shared and networked ÷writing space,ø in the words of Jay Bolter.<sup>5</sup>

But « not every aspect of todayø prevailing hypertext system has been as rosy », they later remark in the introduction to Stuart Moulthropø essay « You

Say You Want a Revolution ».<sup>6</sup> In this essay Moulthrop argues that although hypertext affords new visions about a shared writing space, the responsibility for changes of this magnitude come from a diverse elite (of software developers, literary theorists, legislators, capitalists) who despite their differences remain allegiant to the institutions of intellectual property (the book, the library, the university, the publishing house). In other words, Moulthrop suggests that « it seems equally possible that engagement with interactive media will follow the path of reaction, not revolution. ».<sup>7</sup> The digitisation of text will not only produce a shared writing space, but the implementation of such a system may in the end prove to be reactionary. Through copyrights, patents, and the like the shared space will be restricted.

From our previous studies of the ecology and infrastructure in and around books today, it is evident that e-books and Amazon's Kindle reader not only build upon a tradition of books, and the evolvement of a shared literary writing space but also of software production, including its techniques for restrictions on sharing.<sup>8</sup> As a contrast to Borges's visions of a universe of fiction in which everything can happen, and later Bolter's vision of a shared writing space, the universe of software control is a universe designed to ensure that only things that do not violate copyright and corporate control can happen. The copyrights, trademarks, patents etc. have all been wrapped up in contractual and restrictive end-user licence agreements — a change that has been described with the concept of 'controlled consumption'. In his study on book trade and its impact on literary culture, Ted Striphas launches this concept with inspiration from Henri Lefebvre. Briefly, controlled consumption can be summarized into four principles:

1. A cybernetic industrial infrastructure integrating and handling production, distribution, exchange and consumption is developed around the product.
2. The consumption is controlled through programming that closely monitors consumer behaviour and the effects of marketing through tracking and surveillance.
3. Controlled obsolescence is programmed into the product, limiting the functionality and durability.
4. The overall effect of controlled consumption is a significant reorganizing and troubling of specific practices of everyday life.<sup>9</sup>

Obviously, this scheme of controlled consumption changes literary culture

from a text culture that builds on the principles of sharing through libraries, second-hand selling, as well as intertextuality and quotation to a much more tightly controlled culture based on the copyright of works and corporate control of distribution and consumption through licensing.<sup>10</sup> The licensing culture furthermore includes a thorough monitoring of readers and reading behaviour (e.g. the Amazon Whispernet), which is a sharp turn away from values attached to traditional literary culture such as silent reading and the notions of privacy and freedom that we usually attach to this.

According to Striplas, it does not end with books and cultural content. Similarly to the way, that the printing press earlier was a frontrunner for industrial capitalism (as argued by Ong, see below), book trade now also leads the way, and we see the contours of a new capitalistic system linked to new ways of understanding and using networked information technologies:

Indeed, a society of controlled consumption is premised on a transformation of the figure of the consumer from subject to object of capitalist accumulation this despite the rhetoric of empowerment and interactivity that pervades contemporary media and consumer culture.<sup>11</sup>

In the light of controlled consumption and the empty promises of empowerment and interactivity, print is gaining new importance as a technique that evades the restrictions of the software system, and the transformation of the consumer from subject to object. In general, there is a current tendency of using print in new digital ways of course, drawing on the traditions of artist books, small presses, zines, etc.<sup>12</sup> It seems to be a prevalent cultural dynamics that when a medium loses its prime importance it becomes an object of artistic exploration and resistance (including vinyl, cassette, and other trashed technologies). In this way, new digital books are developed as a contrast to the way the e-book integrate computers and transgresses the mere remediation of books.

Therefore, even though this paper is addressed to the e-lit community, we propose to look at books. By looking at post-digital literary books and the way they critically explore changes in the book's materiality and how this affect literary culture, we will discuss the current cultural and political struggles over the presence and future of literary culture and its business models. In the following, we want to address how a contemporary literary culture is reflecting the current changes by reinvigorating the print book in two different ways:

firstly by conceptually addressing the economic system's commodification of language; and secondly by addressing the material reading experience that we associate with books (and which has been corrupted with corporate monitoring systems such as Amazon's Whispernet).

### **Disruptive Literary Machines**

Through its alphabetic programming, the networked computer is in itself a textual machine, and it is also a prime motor for new and competing forms of text (including hypertext, Post Script, Portable Document Formats, and others). In other words, we are witnessing how the computer becomes entangled in the production and distribution of words and language in new ways. Amazon's many activities are a good example of not only how books can be produced today, but also of how various text production systems function, and are interconnected.

Amazon.com began as a book retailer in the early days of the WWW, but soon expanded its business. Today, it includes their own media platforms: the Amazon Kindle e-book reader, and the Amazon Fire tablet as well print-on-demand and publishing services (Amazon Publishing and Amazon Create Space) with direct sales through to the Amazon Book Store.<sup>13</sup> The collection of data and the ability to nurture on user behaviour seems to lie at the core of Amazon's business. The importance of user evaluation of products is obvious, but to earn money, they also offer the products their customers are most likely to buy. This happens by monitoring patterns in sales (people who buy one book are likely to buy particular other books); and further, disguised in limiting licenses, by connecting their cloud service, Amazon Whispernet to their tablets. This allows them to monitor individual patterns of reading, including what, when, and where the user reads and which notes and underlinings are made.

The historian of print, Walter J. Ong, argues that Gutenberg's printing press was a ground-breaking technology that led to increased literacy, new modes of reading (silent reading) and renewal of institutions around the study and production of text such as the library, the university and other learning institutions. And he further argues that the printing press was the first carrier of industrialised capitalism, leading to a new business around the press of publishers, book-trade, newspapers and magazines with their journalists and critics.

Alphabet letterpress printing, in which each letter was cast on a separate piece of metal, or type, marked a psychological breakthrough of the first order. It embedded the word itself deeply in the manufacturing process and made it into a kind of commodity.<sup>14</sup>

If we are to compare the printing press with our contemporary textual machinery and a production system like Amazon, it is clear that the commodification of words not only happens by their reproduction. Instead, the manufacturing of words has been completely absorbed by complex business structures and computational processes. Amazon is an example of how language itself has become the fuel of a new mode of capitalism (what we say, and what we do, turned into valuable data). Amazon as well as social media, search engines, hypertext, programming languages, and so forth are all examples of how the current ecology of text is expanded and no longer includes just the writing and print of text. Even in the current conquering of the urban, physical space by ubiquitous and mobile computing, we witness a further development of such textual machinery that nurtures on human behaviour as data.

It seems to be a customary cultural dynamics that when artistic ideals (such as an networked, open and shared writing space) become subsumed by capital (as seen in the Amazonic machinery) it calls for counter actions for a literary machine. One example of this is *Dear Jeff Bezos* by Johannes P. Osterhoff. By jailbreaking his Kindle, Osterhoff now mimics the Whispernet and emails data on his reading behaviours directly to Amazon's CEO, Jeff Bezos and simultaneously make them available on the project's website :

Dear Jeff Bezos, I just read «Die Pilgerjahre des farblosen Herrn Tazaki: Roman» by Haruki Murakami until position 1576. Sincerely, Johannes P Osterhoff. Email sent to jeff@amazon.com on Jan 12, 2014 16:59:17 CET.<sup>15</sup>

By doing this, Osterhoff explicitly challenges and reverses the relations between the private and the public in Amazon's Kindle interface, and the value generation attached to this. As he puts it himself:

Companies like Amazon are interested in exclusive ownership of data, because with this exclusivity comes its value. As a user of such services, one loses not only control but also authorship of the data one generated. To



make the data I generate public, is to devalue it. This is why I prefer to share data in an open format.<sup>16</sup>

In *The Project Formerly Known as Kindle Forkbomb*, the artist duo UBERMORGEN.COM was inspired by the negative comments on Rebecca Black's *Friday* YouTube video.<sup>17</sup> In 2012, they collaborated with Luc Gross and Bernhard Bauch to build an Internet robot that could automatically generate books on the basis of YouTube comments on videos and upload them as e-books to Amazon's Kindle bookstore – producing a whole literary ecology including crowds, authors, books, titles, accounts, pricing and a defence system against erasure (Figure 1). In a sense, the system emulates Amazon's own platform.<sup>18</sup>

The books produced by the system appear as staged dramas with actors performing (or rather producing) social media. In *You Funny Get Car* by Nrnick Kencals we meet 13 characters discussing a video in which the teenage pop idol Justin Bieber appears anaesthetised at the backseat of a car.<sup>19</sup> As often on YouTube, the comments are hateful (the comments to Rebecca Black's *Friday* video is another example of this), and sexually harassing Justin Bieber (« when you press eight, thats when biber has a dick rammed up his ass ! »). However, at a closer look, the dialogue is much more complex. Apparently, Bieber's video is part of another phenomenon *Funny or Die*. Funnyordie.com is a website founded by Will Ferrell and Adam McKay at which famous people upload their own funny videos. The videos are rated by the users: the funny ones stay, the others are archived in the -cryptø To further complicate the dialogue in the drama, the characters also discuss the sophistication of Bieber's prank, hinting that he is not acting anaesthetised, but re-enacting another YouTube hit video in which a young boy is on his way home from the dentist.<sup>20</sup>

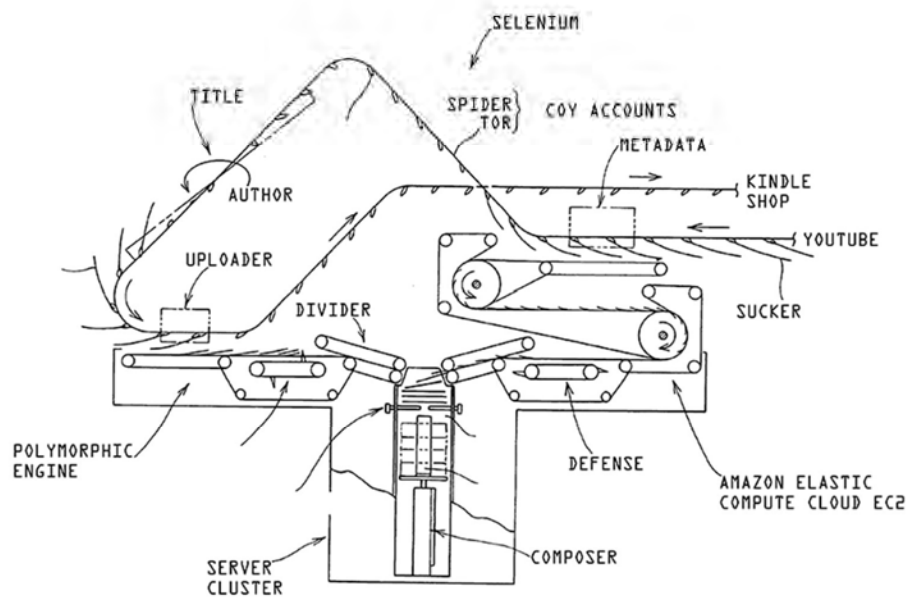

[FIGURE 1]

*The Project Formerly Known as Kindle Forkbomb Printing Press.*

Courtesy of UBERMORGEN and Kunsthal Aarhus,

No Copyright, 2013.

Following the pledge to divert our attention away from media, the digital when discussing e-books (as presented in the introduction), and focus on symbol activity that lies behind, *The Project Formerly Known as Kindle Forkbomb* reveals not only a diagram of book production, but also the symbol activity embedded in the machinery of a contemporary commodification of words. What makes the text is neither the video of Bieber on YouTube, nor its original context at funnyordie.com, nor the video of the anesthetised boy on his way home from the dentist. It is the relations between these texts and the different levels of experiences that makes the text, and which must be seen as a textual and linguistic manifestation of a human reality (human experience, as such, producing meaning).

In a post-structuralist view, the reality of our language is a symbol activity in relation to which the individual is merely a function.<sup>21</sup> In other words,

individual manifestations of language must be separated from language as a symbol activity that structures language and meaning. But whereas the production of meaning in post-structuralism relates to a human condition (language as a human activity), *You Funny Get Car* reveals relations to other modes of production, and in particular the ecology of technological text production: the language act is intrinsically related to the language production evolving around the networked computer: language is both the property of the human and the machine. In this sense, the project aims to work as a -forkbombø in the system, by automatizing the networked processes that produce language today, and turning language against itself. In computing, a forkbomb is a denial-of-service attack, meaning it is a process that continually replicates itself, draining the system of its resources, ultimately causing the system to crash.

In other words, *You Funny Get Car* is an expression of new kind of language production, which mimics the text machinery of the networked computer. It is a work that *produces* reality (rather than depicts), and generally speaking, this kind of productivity has consistently been the object of literary and artistic productivity (a *poiesis*). In this sense, *You Funny Get Car* and *The Project Formerly Known as Kindle Forkbomb* deals with the production of meaning evolving around the networked computer; the language acts of our society, and the ecology of a semio-capitalist text machinery that produces our reality.

### Post-digital books

Other parallel explorations that combine the book format and explorations of networked textual production are currently surfacing. An interesting example is John Cayley and Daniel Howe's *How It Is in Common Tongues* book. The book is a version of Beckett's *How It Is* generated through automated Google searches in a complex process discussing reading and the common text on the internet versus the copyrighted text of Beckett. Consequently, this project instead of Amazon points to Google's fine-tuned and powerful control of language and reading.<sup>22</sup>

Recently, the software theorist Geoff Cox has published a book entitled *Speaking Code*.<sup>23</sup> Amongst other aspects, the book deals with how (in a wider cultural, economical and political context) the formal aspects of computing affect language, and prescribes the human ô for instance how social software combines notions of the public and democracy with a production mode of informational capitalism. In this respect, foregrounding the expressive aspects of

code and the concept of speaking points to a political aspect of artistic coding cultures, and seeks to reinstall the human capacities of thought and expression as the fundamentals for a dynamic society. In other words, in the sphere of networked information technologies — as depicted in the analysis of *The Project Formerly Known as Kindle Forkbomb* — the notion of work is no longer relying on bodies, muscles, and arms (as in industrial capitalism). Also our language mind and emotions are put to work in order to generate value. In this, it is of importance for art to re-accentuate the speaking body, which one could argue otherwise would pervade in front of the computer screen (Geoff Cox refers to the work of —live coding— as an example of this). Following these lines of thinking, another literary response to the post-digital text and language machinery is to focus on the materiality of the book and relating to the pervading perceiving human body.

One mainstream example of how the book is re-invigorated as a medium is found in the popular Harry Potter game *Book of Spells*, developed by Sony in 2012. In it, the user interacts with a magic —Wonderbook— in an augmented reality environment stemming from the book. However, it is not only nostalgia or hipster-like retro-trendiness that leads to renewed interests in the codex, but also an urge to explore alternatives to — and critically reflect upon — the increasingly tightly controlled consumption schemes and their modes of reading and writing that we see in mainstream digitisation of culture.

A more artistic and interesting example is Konrad Korabiewski and Litten's multimedia art book *Affected as Only a Human Being Can Be* (see figure 2).<sup>24</sup> *Affected* is an experimental artist book with graphic works and collages printed with different techniques on various materials, short texts and a soundscape that one can listen to through headphones plugged in to the book's mini-jack. The audio is composed by spatial electronic soundscapes controlled by the turning of pages, and every chapter opens a new soundscape. We hear glitches, drones and loops combined with sounds from nature, shopping centres, rattling locks and wind instruments. Furthermore, short lyrical texts are printed and read aloud. There is no real narrative but a thematic, lyrical theme around social spaces, where meetings are supposed to happen but don't, and the sense of presence is not established. The graphical works of the book consists of abstract, often tactile patterns in dark colours and with photo collages of urban and rural landscapes. In this way, the reading of *Affected* creates an intimate atmosphere with a tint of melancholic loneliness. This intimate reading is emphasized by the surprisingly strong smell of print from the different printing techniques and

paper qualities, the electronic soundscape and the isolation created by the headphones. The result is a tactile, concentrated and intimate reading experience, where the reader is surrounded by the time and space of the book.



[FIGURE 2]

*Affected* with headphones,  
 Courtesy of Konrad Korabiewski & Litten,  
 © Konrad Korabiewski 2014, all rights reserved.

Whereas *Affected* creates a private, intimate reading experience through its way of constructing a new kind of audiobook as a contrast to the often distracted reading at interfaces, the installation *Accidentally, the Screen Turns to Ink* (hereafter *Ink*) is a social installation of digital literature.<sup>25</sup> *Ink* is a performative public display designed to make people affectively engage with, and reflect on, the ergodic qualities of digital literature in public settings. *Ink* has been installed at several libraries, conferences and festivals, including Roskilde Festival in 2012 where more than thousand poems were produced and several thousands were exposed to digital literature for the first time. Through their engagement with *Ink*, people can individually or collaboratively produce poems by

interacting with three books embedded with a custom-made sensor system, the DUL Radio. The interactive books let people control a floating sentence in an ocean of words toward a sheet of paper to produce a poem, all visualized on a large display. The sentences, written by Danish author Peter-Clement Woetmann, are retrieved from a database of about a hundred sentences for each book, which can be manipulated in three variants. When the poem reaches a limit of 350 characters, it is printed out in a form similar to a library receipt for people collect. The poems also appear on a blog ([www.blaek.netlitteratur.dk](http://www.blaek.netlitteratur.dk)) where people can read their own and others' poems, and comment on them.



[FIGURE 3]

*Ink* at Roskilde Library,  
Courtesy of Roskilde Library, (c) Roskilde Library 2014.

Both *Affected* and *Ink* use physical books as interfaces to computers whereas in *Affected* the reading experience is concentrated on the book and the turning of pages, the books in *Ink* cannot be opened or read directly but only through interacting with the installation in a game-like, embodying performance. Moreover, *Ink* is designed to create reflection on the media changes that are challenging a library that for centuries has been adjusted to a traditional book infrastructure with publishers, critics, physical books, shelves, etc. In this way *Ink* is a material reflection on different writing and reading media from books to interfaces and online environments and back again to the printed library receipt. The book as object is a central part of the installation, both as interaction devices

and, on a meta-level, as a comment to the digitization of literature. The books in *Ink* have the immediate appearance of a regular book in terms of shape, the sheets of paper, weight and so forth, however, they cannot be opened and instead function as a controlling device for the text on the screen. This way, *Ink* demands of the reader to find new strategies for *reading* the text. The text is dissociated from the book and appears on the screen, before returning as ink on paper on the library receipt containing the poem and also finding a *digital* home on the associated blog. The graphical interface also makes references to the book; the user produces text on a virtual *piece of paper* floating in a text ocean, and the reader produces text in a process, which is partly inspired by the French author Raymond Queneau's Oulipo technique for his *Cent mille milliards de poèmes* poetry generating book.<sup>26</sup>

In this way the material staging of the installation *including* the interaction books with their game-like interaction, the big display and the two outputs of the final poems *renders* the reading performative and social. The installation is a stage for a collaborative reading and writing experience, where the active users/readers enter a stage with other users *in* the same space but also to some degree online *as* spectating co-readers. In this way, the reader performs as a reader of different related texts: the texts of the three interaction-books, the actual text that she produces through her interaction, and the other texts produced by the installation that she can access on the blog or through the small printed text lying around on the floor from earlier sessions. Given enough time and devotion, the reader consequently becomes a meta-reader developing a multidimensional reading of the installation. From reading the books she starts to make sense of the set-up including the materials from the literary tradition (books, pages, text) *and* the new conditions of, and restrictions to, reading that she is subject to. Furthermore, she does this in a social, public and performative setting, where she performs her reading-writing through an embodied game-like interface, can observe and interact with other reader-writers, and is aware that others are looking over her shoulder and observing her reading-writing performance. In this sense the installation is openly designed for a software-based, social, performative and public reading-writing situation, as a contrast to Amazon's and Google's more closed control systems.

*Affected* and *Ink* both present experiments with using the concrete, physical book as a material (and not only a metaphorical) interface to digitally augmented literary experiences. In this way, they are in contrast to the conservative remediation of the book by e-books, where the interface and reading experience

is designed to be as close as possible to the codex, while all the changes occur behind the reading surface as pointed out through the concept of controlled consumption. *Affected* and *Ink* explore alternatives to the monitoring and controlling of reading that we see in contemporary business models from Amazon, Google and Apple: *Affected* by providing a truly intimate and concentrated reading experience furthered by a focused material experience of the printed book; *Ink* by re-creating a shared, performative «writing space» beyond Amazon's and Google's galaxies of controlled and capitalized text. In this way, both *Affected* and *Ink* — while opposite in their use of books and intimate versus social reading experiences — are examples of a return to the codex in order to rethink the post-digital reader as something other than an « object of capitalist accumulation. »<sup>27</sup>

### **Beyond the Google Galaxy**

The computer is simultaneously a technology of control and a medium of expression. The early computer development mainly took place in military labs as a control technology, but visionaries like Vannevar Bush, Douglas Engelbart, Theodor H. Nelson, Roy Ascott, Allan Kay and Adele Goldberg through the decades developed a new media of expression, which became commercialized by the Californian computer industry giants like Apple and « formed by the braided interplay of technical invention and cultural expression at the end of the 20<sup>th</sup> century. »<sup>28</sup> Art and literature, including hypertext, has played an important part in this development of the computer as a medium of expression and empowerment, as also described by Moulthrop.<sup>29</sup> However, now we seem to have reached a stage, where digital art, literature and culture are no longer just representing alternative uses of computers, but have increasingly become the central data of a new important kind of computers, e.g. tablets, e-books, (and we could add smart phones, game consoles, smart-TV boxes, etc.). Cultural computing has become big business, but while we get a lot of cultural content on our computer screens, it is followed by control, monitoring and capitalization behind the screen, as we have argued through the concept of controlled consumption. Furthermore, cultural computing is currently often designed as conservative remediations relating to traditional media practices and business models, often even more confined in relation to free use and sharing. Designs such as the Kindle and the iPad are not adopting the more radical developments within digital culture, art and literature, but aiming to preserve and confine



traditional cultural practices.

Consequently, in our post-digital print culture, the challenge for digital literature is less to get beyond the Gutenberg Galaxy of the printed book, as it was for hypertext theory and practice like Bolter and Landow more than twenty years ago.<sup>30</sup> Currently, the most urgent challenge is to get beyond the Google galaxy of controlled text, the Amazonic textual machinery, the infrastructures of controlled consumption. To quote Stuart Moulthrop's uncannily topical warning against blind belief in technological progress, written in 1991: « Taken to its limits, hypertext could reverse/recourse into a general medium of control, a means of ensuring popular franchise in the new order of virtual space. »<sup>31</sup> The once utopian and revolutionary visions of hypertext and the Internet are currently in danger of shifting into controlled consumption and Web 2.0 capitalism.<sup>32</sup> In the light of this, the contemporary challenge for digital literature is to critically explore and address the textual machinery of controlled consumption in order to find out how it controls and capitalizes meaning, reading and writing ó and create alternatives.

**Acknowledgements:** Thanks to the collaborators on *Ink* (Jonas Fritsch, Lasse Steenbock Vestergaard, Martin Campostrini, Allan Thomsen Volhøj, Ann Luther Petersen, Rune Wehner, Jonas Oxenbøll Petersen, Janus Bager Kristensen and Rolf Bagge). Also thanks to the projects Litteraturen finder sted (Literature Takes Place), Disruptive Innovation in Digital Art-Activism and Business, Aarhus University's Participatory IT Research Center and CAVI for supporting the development and research.

## NOTES

<sup>1</sup> Bolter, J. David. *Writing Space the Computer, Hypertext, and the History of Writing*, Hillsdale, N.J.: L. Erlbaum Associates, 1991.

<sup>2</sup> Ludovico, Alessandro. *Post-Digital Print — the Mutation of Publishing since 1894*, Eindhoven: Onomatopee, 2012.

<sup>3</sup> Cascone, Kim. « The Aesthetics of Failure: « Post-Digital » Tendencies in Contemporary Computer Music. » *Computer Music Journal* (24/4, 2000), 12.

<sup>4</sup> Ludovico, Alessandro. *Post-Digital Print — the Mutation of Publishing since 1894*, Eindhoven : Onomatopee, 2012. *Ibid.*, 163.

<sup>5</sup> Montfort, Nick and Noah Wardrip-Fruin. *The New Media Reader*, Cambridge, Mass.: MIT Press, 2003, 29.

<sup>6</sup> Moulthrop, Stuart. « You Say You Want a Revolution? Hypertext and the Laws of Media. » *The New Media Reader*, ed. Noah Wardrip-Fruin & Nick Montfort Cambridge, Massachusetts & London, England: The MIT Press, 2003 (1991), 691.

<sup>7</sup> *Ibid.*, 703.

<sup>8</sup> Andersen, Christian Ulrik and Søren Bro Pold. « Controlled Consumption Culture: When Digital Culture Becomes Software Business. » *The Imaginary App*, Svitlana Matviyenko and Paul D. Miller, eds., Cambridge, Mass.: MIT-Press, 2014: 17-33.

<sup>9</sup> Striplhas, Ted. *The Late Age of Print: Everyday Book Culture from Consumerism to Control*, New York : Columbia University Press, 2011, 180-82.

<sup>10</sup> See also Barthes' classic distinction between *œuvre* and *texte* Barthes, Roland. « From Work to Text. » *The Rustle of Language*, Richard Howard, trans., Berkeley & Los Angeles : University of California Press, 1989.

<sup>11</sup> Striplhas, Ted. *The Late Age of Print: Everyday Book Culture from Consumerism to Control*, New York : Columbia University Press, 2011. *Ibid.*, 183.

<sup>12</sup> See Ludovico, Alessandro. *Post-Digital Print — the Mutation of Publishing since 1894*, Eindhoven: Onomatopee, 2012. There are several examples of hactivist approaches to self-publishing: in the *Peer-reviewed Newspaper*, which was initiated by Geoff Cox and Christian Ulrik Andersen, we find the self-publication and self-organized peer-review of academic resources, and in *The Heath Bunting* collection, we find the production of promissory bank notes.

<sup>13</sup> In addition, Amazon is a provider of cloud services (including Whispernet), a

retailer of all sorts of consumer goods (furniture, shoes, etc.), a main provider of crowd-sourced production (Amazon Mechanical Turk), and much more.

<sup>14</sup> Ong, Walter J.. *Orality and Literacy*, London & New York: Routledge, 1988, 116.

<sup>15</sup> Osterhoff, Johannes P.. *Dear Jeff Bezos*, 2013-14, Available: <http://bezos.cc>.

<sup>16</sup> Osterhoff quoted by Fino-Radin, Ben. « Title. » *Rhizome Editorial*, New York: 2013.

<sup>17</sup> The music video was a viral phenomenon on YouTube receiving massive attention for being the worst song ever. This included hundreds of thousands hateful comments and numerous parodies with equal popularity.

<sup>18</sup> UBERMORGEN.COM later parted with Gross and Bauch, who released their own version of the project as *Kindle'voke Ghost Writers* (<http://traumawien.at/ghostwriters/>), and hence, the current project is now entitled *The Project formerly known as Kindle Forkbomb*. It is currently disputed who is the originator for the project since these two versions exist. We do not wish to pass any judgement on this issue, but have mainly worked with UBERMORGEN.COM's version, which includes the diagrams we reproduce in this article.

<sup>19</sup> Kencals, Nrlnick. *You Funny Get Car*, :() { :|:& } ;:, Ubermorgen.com, 2012. The original YouTube video of Justin Bieber (*Bieber after the Dentist*) can be found at <http://www.youtube.com/watch?v=upaJHS8mfP8>.

<sup>20</sup> The origin of Bieber's parody (*David After Dentist*) can be found at <http://www.youtube.com/watch?v=txqiwrbyGrs> (and has received more than 118 million views).

<sup>21</sup> Egebak, Niels. *Anti-Mimesis : Essay*, Aarhus: Copenhagen: Arena, 1970, 9.

<sup>22</sup> Cayley, John and Daniel C. Howe. *How It Is in Common Tongues*, Providence: The Natural Language Liberation Front, 2012. Other interesting projects that explore Google's effect on language are Christophe Bruno's *Iterature* and *Dadamap* projects, which we have discussed elsewhere. See Pold, Søren, « Literature from Page to Interfac: The Treatments of Text in Christophe Bruno's Iterature. » *Electronic Book Review* (2007), Andersen, Christian Ulrik and Søren Pold. « The Marketization of Net Art. » *Peer-reviewed Newspaper* (2/1, 2013).

<sup>23</sup> Cox, Geoff and Alex McLean. *Speaking Code: Coding as Aesthetic and Political Expression*, Cambridge, Mass.: The MIT Press, 2013.

<sup>24</sup> Korabiewski, Konrad and Litten. *Påvirket Som Kun Et Menneske Kan Være*, Aarhus: Geiger Records, 2010. Currently it only exists in Danish, but an English

version should be forthcoming.

<sup>25</sup> Woetmann, Peter-Clement, Jonas Fritsch, Lasse Steenbock Vestergaard, Søren Pold, Martin Campostrini, Allan Thomsen Volhøj, Ann Luther Petersen, Rune Wehner, Jonas Oxenbøll Petersen, Janus Bager Kristensen and Rolf Bagge. *Tilfældigvis Er Skærmen Blevet Blæk*, Aarhus : Litteraturen finder sted, Roskilde Bibliotekerne, CAVI, PIT, 2012-13.

<sup>26</sup> Queneau, Raymond. *Cent Mille Millions De Poèmes*, Paris : Gallimard, 1961.

<sup>27</sup> Striphas, Ted. *The Late Age of Print: Everyday Book Culture from Consumerism to Control*, New York: Columbia University Press, 2011. *Ibid.*, 183.

<sup>28</sup> Murray, Janet. « Inventing the Medium (Introduction), » *The New Media Reader*, Noah Wardrip-Fruin and Nick Montfort, eds., Cambridge, Massachusetts & London, England : The MIT Press, 2003, 3.

<sup>29</sup> Moulthrop, Stuart. « You Say You Want a Revolution? Hypertext and the Laws of Media, » *The New Media Reader*, Noah Wardrip-Fruin and Nick Montfort, eds., Cambridge, Massachusetts & London, England: The MIT Press, 2003 (1991).

<sup>30</sup> Bolter, J. David. *Writing Space the Computer, Hypertext, and the History of Writing*, Hillsdale, N.J.: L. Erlbaum Associates, 1991, Landow, George P., *Hypertext the Convergence of Contemporary Critical Theory and Technology*, Baltimore, Md: Johns Hopkins University Press, 1992.

<sup>31</sup> Moulthrop, Stuart. « You Say You Want a Revolution? Hypertext and the Laws of Media, » *The New Media Reader*, Noah Wardrip-Fruin and Nick Montfort, eds., Cambridge, Massachusetts & London, England: The MIT Press, 2003 (1991). *Ibid.*, 703.

<sup>32</sup> Furthermore, this monitoring apparently feeds directly into US military intelligence, as the recent disclosures by Edward Snowden on the US intelligence agency NSA's Prism programme shows. Consequently, it seems that we have come full circle back to the computer as a military technology of control again.